



P1909181

CANTONI & C
BOFFALORA-T. (MI) ITALY

REAR TIPPER

“DF ROCCIA”

TGS 41.400 8x4 BB-WW



10630321

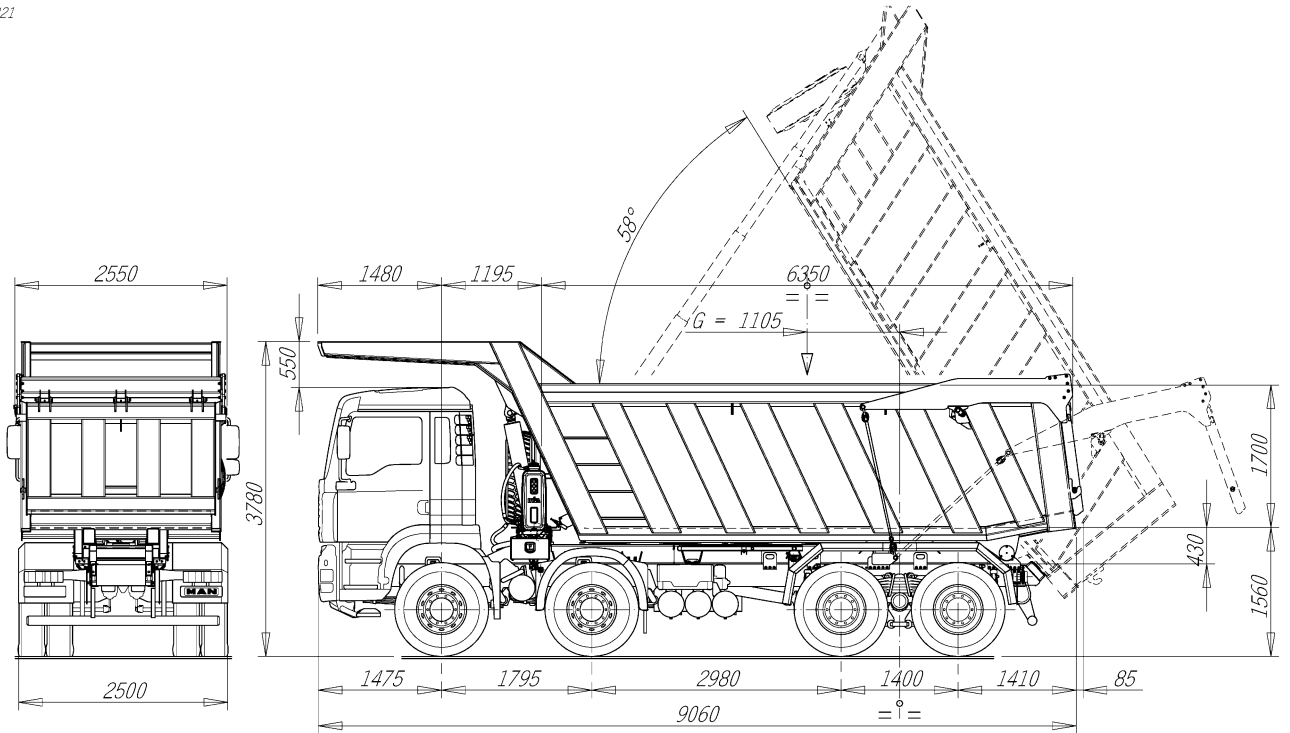

TECHNICAL DATA



- LIFTING** :
- Frontal telescopic cylinder.
 - Pneumatic, modulated body descent control.
 - Rubber safety stoppers at the end of tilting.
 - Stabiliser bar.
 - Tipping time: 30 sec

- SUBFRAME** :
- Side frame in bent steel sheet.
 - Anti-torsion cross-member in the back side.
 - Mixed type frame fixing (front screws with springs).

- DUMP-BODY:**
- Capacity, 22 cu.m.
 - Inside width, 2160 mm
 - Special reinforced structure for rock transport.
 - Structure in bent steel sheet.
 - Body floor in antiabrasion steel (HB 450), thickness 12 mm
 - Boards in antiabrasion steel (HB 400), thickness 8 mm
 - Front board equipped with cab protection roof and spare wheel holder.
 - Fixed sideboards.
 - Inclined rear side of the body.
 - Rear board with automatic opening device, by chains.

WEIGHTS (kg)

Dump body	8700
Net weight of the dump truck.....	19350
Payload	24650
G.V.W	44000

- Dimensions and weights are not binding and may undergo variations.